

Robin W1G LiDAR

Robin W1G is an automotive-grade LiDAR system developed by Seyond, offering an ultra-wide 120° x 70° (HxV) field-of-view(FOV) and a distance range twice that of similar products on the market while achieving a 10cm minimum distance. Robin W1G is able to withstand harsh environmental conditions while continuing to deliver a high quality point cloud, delivering superior reliability and product lifetime. Robin W1G is used in automotive (AD/ADAS) sectors, construction machinery, low-speed vehicles, robotics, Intelligent Transportation Systems and Smart Infrastructure.



Specifications

LiDAR PERFORMANCE	
Laser Wavelength	905 nm
FOV (H*V)	120°*70°
Angular Resolution (H*V)	0.15°*0.36°
Detection Range	70 m, POD>90% (10% Lambertian reflectivity @ 10 Hz)
Detection Range (Maximum)	150 m
Detection Range (Minimum)	0.1 m
Range Precision	Up to 1 cm @1σ
Range Accuracy	± 2 cm
Frame Rate	10 to 20 FPS
OPERATIONAL/ELECTRICAL	
Operating Voltage	9 to 34 V DC
Operating Temperature	-40 °C to +85 °C
Rated Power	<7.2 W
Operating Current	<0.6 A@12 V
Ingress Protection	IP67(body), IP69K(window)
Laser safety	Class 1 (IEC-60825)
MECHANICAL	
Dimensions (H × W × D)	85 mm × 104.8 mm × 106.7 mm
Weight	800 g
Connector	Proprietary pluggable connector (Power + Automotive Ethernet + CAN-FD)
TRANSMISSION	
Data Interface	1000BASE-T1 (Data: UDP, Control: TCP)
Data Output	Distance, Reflectance, Horizontal & Elevation angle, Timestamp
Points Per Second	1.28M (single return@10Hz)
Communication bandwidth	60Mbps (single return)
Time Synchronization	gPTP / PTP / NTP
Echo Mode	Single/Dual returns

Dimensions (Unit: mm)

* This size is the maximum size without connector in three dimensions.

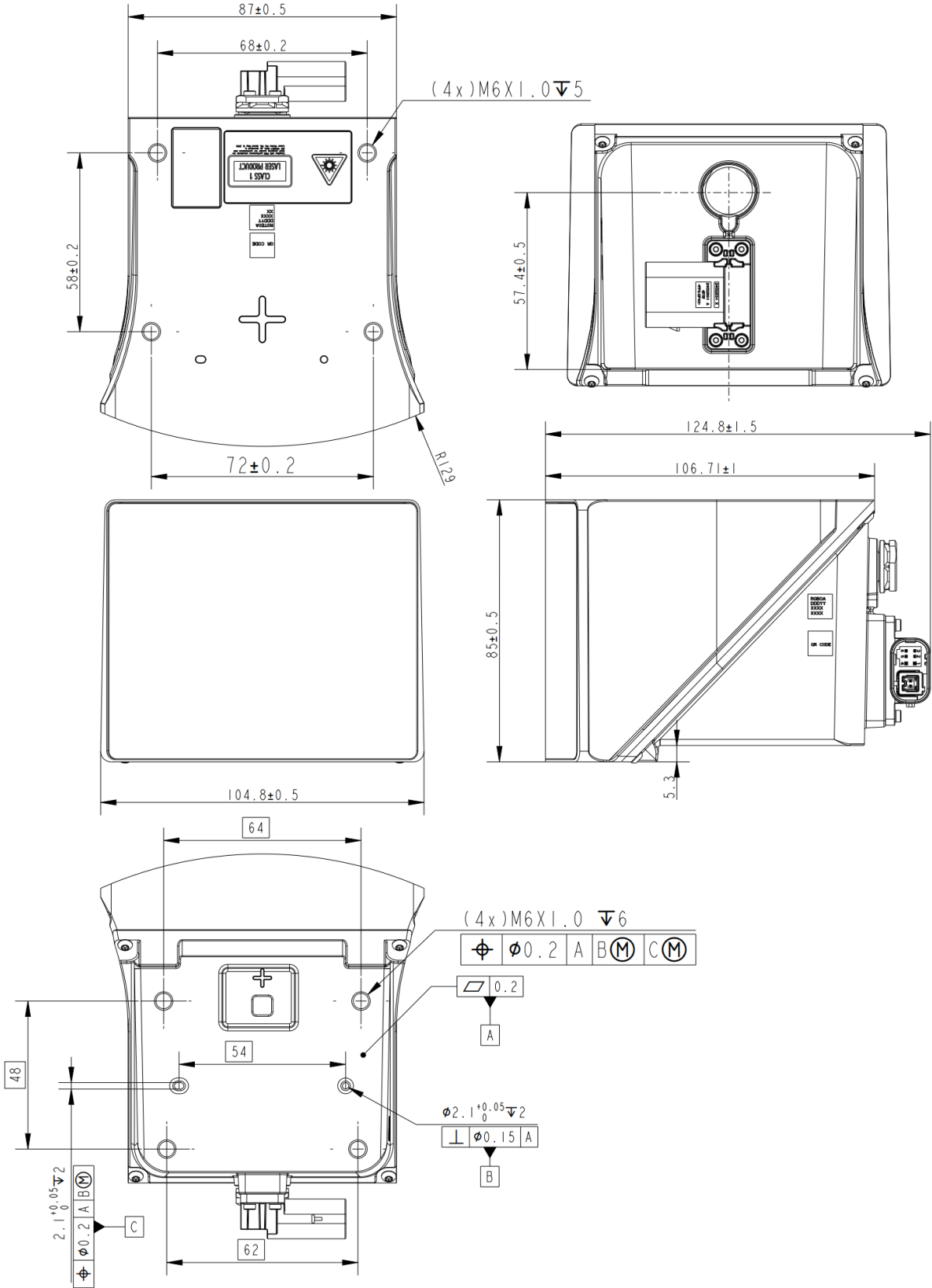

*Specifications are subject to change without notice and based on engineering targets. Specs are not guaranteed to have passed full validation at the time of publication.